



ELECTRONIC

PRODUCT OVERVIEW :

Designed around the exact footprint of their magnetic ballast counterparts, Advance's **AmbiStar** electronic ballasts for T8 fluorescent lamps represent an easy-to-install, energy-efficient replacement solution which optimizes lighting applications in the residential and hospitality sectors.

Ideal for applications such as kitchens, bathrooms, basements, and garages, **AmbiStar** electronic ballasts are Class B FCC EMI rated and EPA ENERGY STAR® Residential Lighting Fixture Program listed for reliable operation in residential settings. Available in popular 17 Watt, 25 Watt, and 32 Watt versions, the ballasts' electronic circuitry provides comfortable and quiet performance.

Low-maintenance and high-performing, **AmbiStar** electronic ballasts for T8 fluorescent lamps offer residential and hospitality users a versatile and high-quality T8 lighting solution which drives reductions in energy consumption and costs while promoting environmental sustainability.

AmbiStar™

Electronic Ballasts for T8 Fluorescent Lamps



DESIGN HIGHLIGHTS:

- Class B FCC EMI Rating
 - Requirement for the EPA ENERGY STAR residential lighting fixtures
- Title 24 Energy Efficiency Requirements
 - For use in high efficiency residential fixtures as stated in California's Title 24 requirements
- Electronic circuitry
 - Enables ballasts to run cooler and operate quieter than many magnetic ballast alternatives
- Operation above 40kHz
 - Avoids interference with infrared control systems
 - Delivers quiet, flicker-free performance
- Lamp ignition in less than 1.0 second
 - Provides flicker-free starting
- Auto restart circuit
 - Eliminates the need to reset power mains after failed lamps are replaced
- Identical mounting to standard magnetic ballast design
 - Enhances ease of installation in retrofit applications

APPLICATIONS:

■ Residential

■ Hospitality



No. of Lamps	Input Volts	Lamp Starting Method	Ballast Family	Catalog Number	Input Power ANSI (Watts)	Ballast Factor	Max. THD %	Line Current (Amps)	Min. Starting Temp. (°F/°C)	Dim.	Wiring Dia.
F17T8 (24")											
1	17	120	AmbiStar	REB-2P32-SC	19	1.02	150	0.30	0/-18	A	*64
2	17	120	AmbiStar	REB-2P32-SC	31	0.91	140	0.45	0/-18	A	64
3	17	120	AmbiStar	REB-4P32-SC	44	0.81	135	0.87	0/-18	A	*66
4	17	120	AmbiStar	REB-4P32-SC	52	0.82	135	1.00	0/-18	A	66
F25T8 (36")											
1	25	120	AmbiStar	REB-2P32-SC	26	1.00	150	0.39	0/-18	A	*64
2	25	120	AmbiStar	REB-2P32-SC	43	0.89	130	0.61	0/-18	A	64
3	25	120	AmbiStar	REB-4P32-SC	63	0.86	125	1.14	0/-18	A	*66
4	25	120	AmbiStar	REB-4P32-SC	77	0.81	125	1.31	0/-18	A	66
F32T8 (48")											
1	32	120	AmbiStar	REB-2P32-SC	33	1.00	140	0.48	0/-18	A	*64
2	32	120	AmbiStar	REB-2P32-SC	56	0.88	120	0.80	0/-18	A	64
3	32	120	AmbiStar	REB-4P32-SC	80	0.84	125	1.36	0/-18	A	*66
4	32	120	AmbiStar	REB-4P32-SC	103	0.81	125	1.57	0/-18	A	66

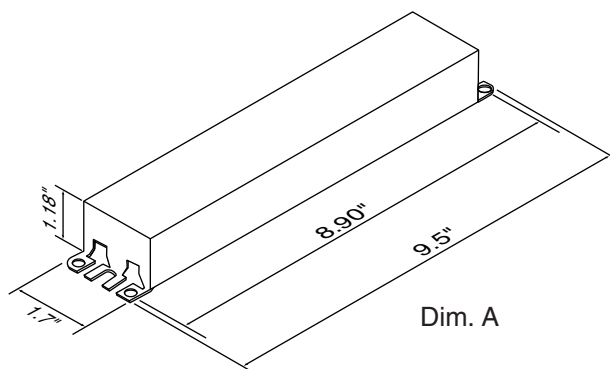

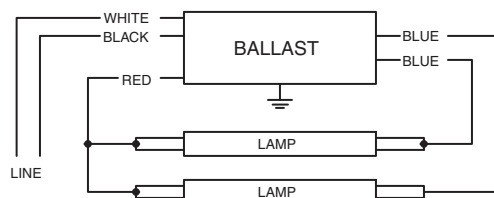

Diag. 64

* For single lamp operation, insulate unused blue lead for 600 volts

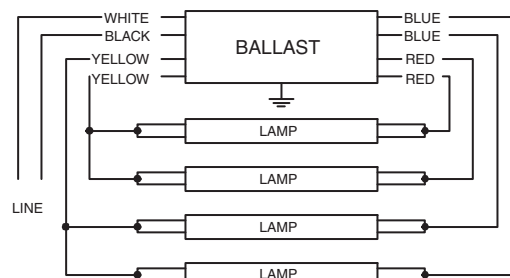

Diag. 66

* For three lamp operation, insulate unused blue lead for 600 volts

Section I - Physical Characteristics

- 1.1 Ballast shall be physically interchangeable with standard electromagnetic or standard electronic ballasts, where applicable.
- 1.2 Ballast shall be provided with integral leads color coded per ANSI C82.11.

Section II - Performance Requirements

- 2.1 Ballast shall be Instant Start.
- 2.2 Ballast shall provide Independent Lamp Operation (ILO) allowing remaining lamp(s) to maintain full light output when one or more lamps fail.
- 2.3 Ballast shall contain auto restart circuitry in order to restart lamps without resetting power
- 2.4 Ballast shall operate from 60 Hz input source of 120V with sustained variations of +/- 10% (voltage and frequency).
- 2.5 Ballast shall be high frequency electronic type and operate lamps at a frequency above 42 kHz to avoid interference with infrared devices and eliminate visible flicker.
- 2.6 Ballast shall have a Power Factor greater than 0.50 for primary lamp.
- 2.7 Ballast shall have a minimum ballast factor of 0.85 for primary lamp.
- 2.8 Ballast shall provide for a Lamp Current Crest Factor of 1.7 or less in accordance with lamp manufacturer recommendations.
- 2.9 Ballast input current shall have Total Harmonic Distortion (THD) of less than 150% when operated at nominal line voltage with primary lamp.
- 2.10 Ballast shall have a Class A sound rating.
- 2.11 Ballast shall have a minimum starting temperature of 0°F/-18°C for primary lamp.
- 2.12 Ballast shall tolerate sustained open circuit and short circuit output conditions.

Section III - Regulatory Requirements

- 3.1 Ballast shall not contain any Polychlorinated Biphenyl (PCB).
- 3.2 Ballast shall be Underwriters Laboratories (UL) listed, Class P and Type 1 Outdoor; and Canadian Standards Association (CSA) certified, where applicable.
- 3.3 Ballast shall comply with ANSI C62.41 Category A for Transient protection.
- 3.4 Ballast shall comply with ANSI C82.11 where applicable.
- 3.5 Ballast shall comply with the Federal Communications Commission (FCC), Title 47 CFR part 18, Consumer (Class B) for EMI/RFI (conducted and radiated).

Section IV - Other

- 4.1 Ballast shall be manufactured in a factory certified to ISO 9001 Quality System Standards.
- 4.2 Ballast shall carry a two-year limited warranty from date of manufacture to be free from defects in material and workmanship, under certain conditions, including, but not limited to operation at a maximum case temperature of 70°C.
- 4.3 Manufacturer has a fifteen-year history of producing electronic ballasts for the North American market.



Advance • 10275 W. Higgins Road • Rosemont, IL 60018
Tel: 800-322-2086 • Fax: 888-423-1882
Customer Support/Technical Service: 800-372-3331
OEM Support: 866-915-5886

www.advancetransformer.com



© 2008 Advance, A Division of Philips Electronics North America
All rights reserved. Reproduction in whole or part is prohibited without the prior written consent of the copyright owner. The information presented in this document, is believed to be accurate and reliable and may be changed without notice. No liability will be accepted by the publisher for any consequences of its use. Publication thereof does not convey nor imply any license under patent or other industrial or intellectual property rights.

Form No. EL-2440-R03 4/08